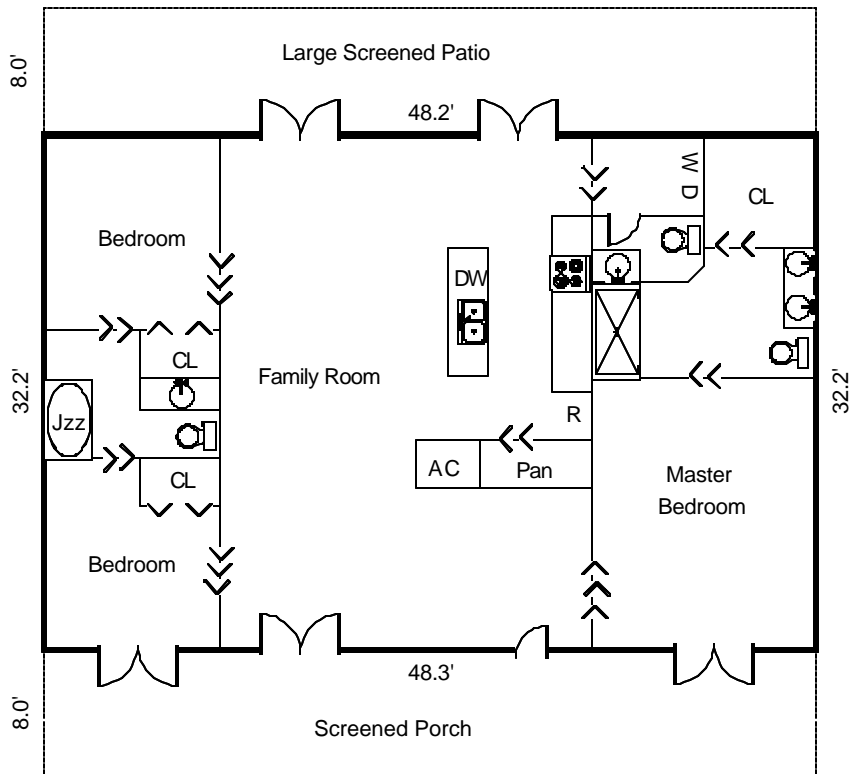

SKETCH/AREA TABLE ADDENDUM

SUBJECT

Property Address 253 Curley Seal	State MS	Zip 39466
City Picayune		
Borrower		
Lender/Client		
Appraiser Name		

IMPROVEMENTS SKETCH

Comments:

AREA CALCULATIONS

AREA CALCULATIONS SUMMARY			
Code	Description	Net Size	Net Totals
GLA1	First Floor	1552.0	1552.0
P/P	Screened Porch	386.0	
	Large Screened Patio	386.0	772.0
Net LIVABLE Area		(Rounded)	1552

LIVING AREA BREAKDOWN		
Breakdown	Subtotals	
First Floor	32.2 x 48.3	1552.0
1 Item	(Rounded)	1552